



# Voltage performance enhancement of DFIG-based wind farms integrated in large-scale power systems: Coordinated AVR and PSS



Rahmat Khezri\*, Hassan Bevrani

Department of Electrical and Computer Engineering, University of Kurdistan, Sanandaj, PO Box 416, Kurdistan, Iran

## ARTICLE INFO

### Article history:

Received 19 May 2014

Received in revised form 2 May 2015

Accepted 5 May 2015

Available online 25 May 2015

### Keywords:

DFIG-based wind farms

Voltage performance enhancement

AVR

PSS

Fuzzy coordinator

## ABSTRACT

According to large extension of Doubly-fed induction generators (DFIGs) in power systems, providing appropriate operating condition for this type of wind technology in fault situations seems necessary. Among the essential requirements for DFIGs in fault situations, low-voltage ride-through (LVRT) capability is the utmost important issue. This paper deals with voltage performance enhancement of DFIG-based wind farms integrated in large-scale power systems under voltage dips. This aim is satisfied by create coordination between automatic voltage regulator (AVR) and power system stabilizer (PSS) of synchronous generators. In this research, the key tool for the coordination is fuzzy logic. The necessity of coordination for the designed fuzzy controller (fuzzy coordinator) is to eradicate destructive interactions between AVR and PSS in grid disturbance conditions. The fuzzy coordinator adjusts the AVR and PSS gains to enforce them to give the best performance in fault situations. The proposed coordination supports the voltage mitigation in the Point of common coupling (PCC) under voltage dips and decreases the reactive power requirement of the DFIGs. The performance of the designed fuzzy coordinator is demonstrated on the IEEE 10-machine 39-bus power system with different levels of DFIG-based wind farms contribution.

© 2015 Elsevier Ltd. All rights reserved.

## Introduction

Widespread development in utilizing renewable energy resources such as solar, marine, biomass, geothermal and wind for electricity generation is become inescapable newly. Wind energy has the most contribution for power generation among different renewable energy resources; this is so because of its potential advantageous such as free availability of wind, ability to exploit in high power, other land around uses of wind farms and as the important one it is relatively inexpensive to build wind farm [1]. Targets in Europe and the US in 2007 for wind installation will meet 20% of their electricity consumptions by 2030 [2]. Application of this amount of wind power in electrical power systems requires more accuracy and attention. Great information about large integration of wind plants, impacts on power system and deregulated systems has been given by [3].

With introduction of new generation concepts such as Doubly-fed induction generators (DFIGs) with different dynamics of synchronous generators, the stability of power system is confronted to new challenges. When the contribution of DFIGs in power system is in small scale, the stability of power system is affected lowly. On the contrary, with high penetration of

DFIG-based wind farms in the power system, the dynamic performance of the grid can be affected significantly by the characteristics of the DFIGs. The transient stability of power systems integrated with DFIGs is investigated in several papers [4,5]. The increased integration of DFIG-based wind farms in power systems can have both beneficial and detrimental effects on small signal stability and transient stability [6]. The safe application without reducing stability of DFIGs equipped with power electronic converter and Low-voltage ride-through (LVRT) capability in a weak grid is demonstrated in [7]. The relation between reactive power control of DFIGs and the rotor angles of synchronous generators in a large-scale power system is addressed in [8]. Reduction in reactive power absorption of DFIGs can diminish reactive power injection by the synchronous generators and helps mitigation large rotor angle swings.

Since that rotor speed of DFIG-based wind turbine changes to extract maximum energy from wind, the LVRT enhancement gains the most attention. In a power system with wind farms, faults even far away from the location of wind farms can cause voltage dips in the terminals of wind turbine. The current in the stator windings of DFIG will increase rapidly after voltage dip in the Point of common coupling (PCC). The magnetic coupling between stator and rotor of induction generator in DFIG causes to flow a current in the rotor circuit. As a result, the overcurrent will be seen in power electronic converter, which may destroy the converter. Given this assertion,

\* Corresponding author. Tel.: +98 444 4622465.

E-mail address: [r.khezri.2014@ieee.org](mailto:r.khezri.2014@ieee.org) (R. Khezri).

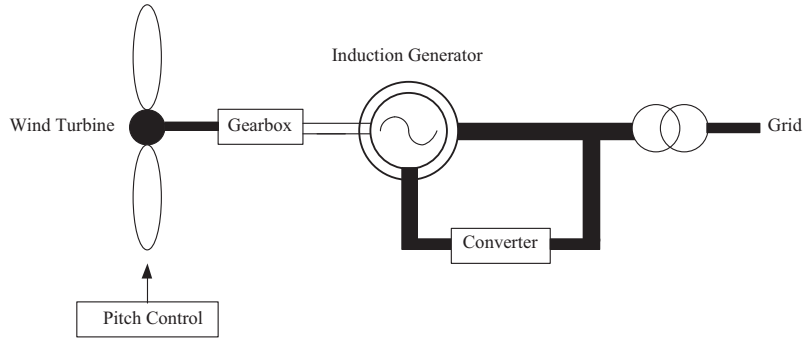

Fig. 1. DFIG model.

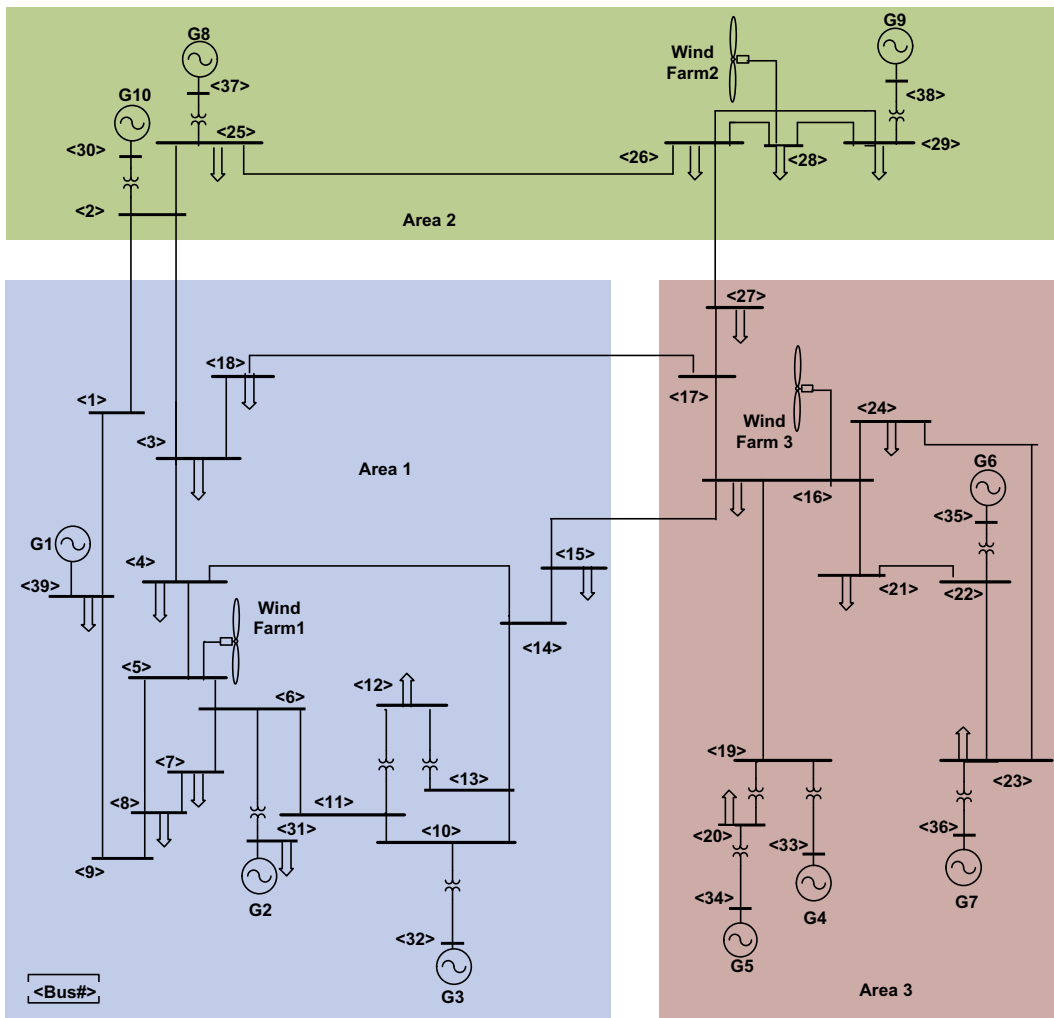

Fig. 2. 39-bus power system.

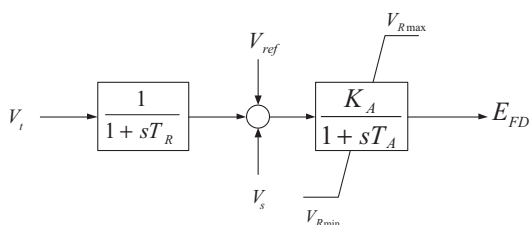

Fig. 3. AVR structure.

most of the studies in the published literature are limited to PCC voltage performance enhancement of DFIGs. To achieve this end, there are two control strategies: from the network point of view, the available control tools such as AVR, PSS and dynamic voltage controllers can be employed. On the other hand, from the DFIG point of view, different control plans can be implemented on the power electronic converter to enhance the PCC voltage.

Using a series damping resistor in the stator circuit, the peak of rotor current in fault situation is reduced in [9]. A robust decentralized output feedback control scheme for rotor-side and grid-side

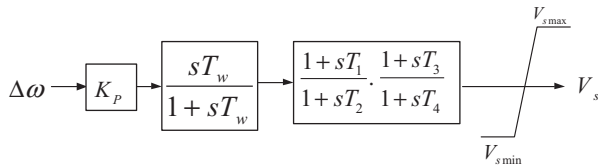

Fig. 4. PSS structure.

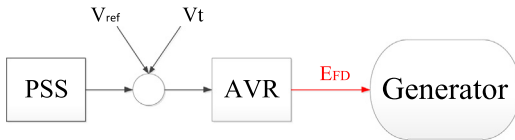

Fig. 5. Mode of operation.

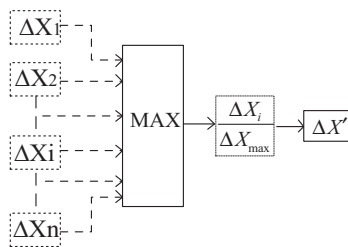

Fig. 6. Normalization method.

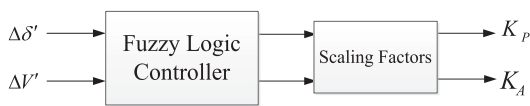

Fig. 7. Fuzzy coordinator.

converters of DFIG is proposed in [10] to enhance the LVRT. However, the controller performance is limited to the post-fault operating point of system to perch in the region which the controller is designed. Ref. [11] advocates that the configuration of DFIGs based on control features improves the voltage stability margin of power system in both distribution and transmission levels. An advanced LVRT control scheme is proposed in [12] to improve the reactive power support ability for a DFIG under voltage sags. A passive compensator in series with stator windings and an active compensator through rotor voltage control are realized in Ref. [13] to improve the LVRT capability of DFIG. A controller with different abilities which is designed for DFIG-based wind turbine for positive contribution of DFIG in power network operation is given in [14]. The controller provides suitable voltage control and voltage recovery in fault situations.

Dynamic voltage support and reactive power compensation through Flexible AC transmission system (FACTS) devices is other way to enhance the voltage performance of wind turbines during voltage dips. Impacts of different types of FACTS devices on stability of power system connected with wind energy conversion systems is established in [15]. Also, a great analysis about impacts of large compensation by FACTS devices in high penetration of wind farms on power system dynamic performance is investigated in [16]. It is shown in [16] that due to local application and uncoordinated control strategies of FACTS devices in power systems, destabilizing interactions are possible. Also, it is highlighted that large compensation with FACTS can reduce the security limit under certain operating conditions. Most of the studies in the published literature are limited to Static synchronous compensator application for stability and voltage performance enhancement in a power system with penetration of DFIGs [17–20].

Nowadays, with high penetration levels of DFIG-based wind farms in large-scale power systems, appropriate voltage control in DFIG’s terminal looks essential. As a common objective, the controllability of converters can be used to achieve voltage recovery in voltage dips, but the capacity of these converters in DFIG technology is limited. The given drawback can inhibit to give best performance of the converters in drastic fault situations for high penetration levels of DFIGs in power system. A comprehensive survey on the impacts of renewable energy options on frequency stability is given in [36].

In this research, the control of synchronous generators in multi-machine power systems is employed to enhance the voltage performance in PCC of DFIGs. Automatic voltage regulator (AVR) and Power system stabilizer (PSS) are installed on the synchronous generators in power system over the years [21]. Voltage regulation, transient and small-signal stability improvement are the main tasks of these two controllers in the system. It is noteworthy that, the output signal of AVR and PSS has voltage gender. Therefore, the effect of them on voltage performance has a better prestige. Both PSS and AVR are designed for nominal operating point of system [22]. Thereby, the controllers can be coordinated for fault situations. In the present work, the fuzzy logic is used to create coordination between the AVR and PSS. Normalized deviations of rotor angle and terminal voltage of synchronous generators in the power system have been selected as input signals for the fuzzy coordinator unit. At the same time and with appropriate fuzzy rules, the fuzzy coordinator generates acceptable gains for the AVR and PSS. The prominent point about this fuzzy coordinator is that, it is not need to install the fuzzy coordinator on all of the existing generators in a large-scale power system. The efficiency and robustness of coordinator is investigated in various penetration levels of DFIG-based wind farms in 39-bus power system for voltage performance enhancement in PCC of wind farms.

The paper is organized as follows: The models of DFIG, power system and controllers are described in Section ‘System model and description’. The coordination necessity is discussed in Section ‘Coordination necessity’. Section ‘Fuzzy coordinator’ explains

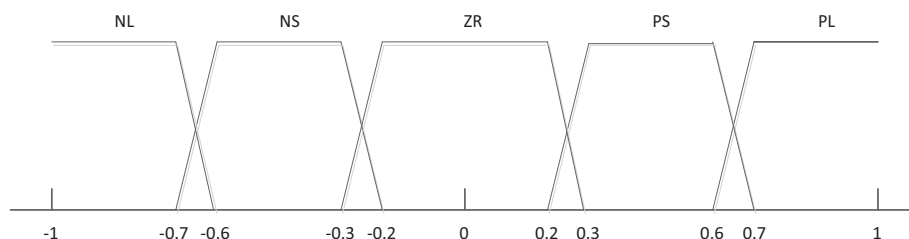

Fig. 8. Membership function for inputs and outputs variables.

**Table 1**  
Fuzzy rule table for, (a) PSS gain and (b) AVR gain.

KP		$\Delta V$				
		NL	NS	ZR	PS	PL
<i>(a)</i>						
$\Delta\delta'$	NL	PS	ZR	ZR	NS	NS
	NS	PL	PS	ZR	ZR	PS
	ZR	ZR	ZR	NS	ZR	ZR
	PS	PS	NS	ZR	PS	PS
	PL	NS	ZR	PS	ZR	NL
KA		$\Delta V$				
		NL	NS	ZR	PS	PL
<i>(b)</i>						
$\Delta\delta'$	NL	PL	PL	PS	ZR	NS
	NS	PL	PS	PS	PS	ZR
	ZR	PS	PS	PS	PS	ZR
	PS	NS	NS	NL	NL	NL
	PL	PS	PS	ZR	PL	NL

the fuzzy approach and fuzzy coordinator structure. Simulation results on 39-bus power system with different types of DFIGs utilization are demonstrated in Section ‘Simulation results’, and finally, conclusions are presented in Section ‘Fuzzy coordinator’.

**System model and description**

Brief descriptions about DFIG, 39-bus power system, AVR and PSS models are given below. All of these systems have been modeled in SIMULINK environment of MATLAB.

*DFIG*

The configuration of DFIG, which corresponds to a variable speed wind turbine with a wound rotor induction generator and a partial-scale power converter, is illustrated in Fig. 1. DFIG is the most popular type of wind generator among the technologies that have been employed for wind power generation. The DFIG

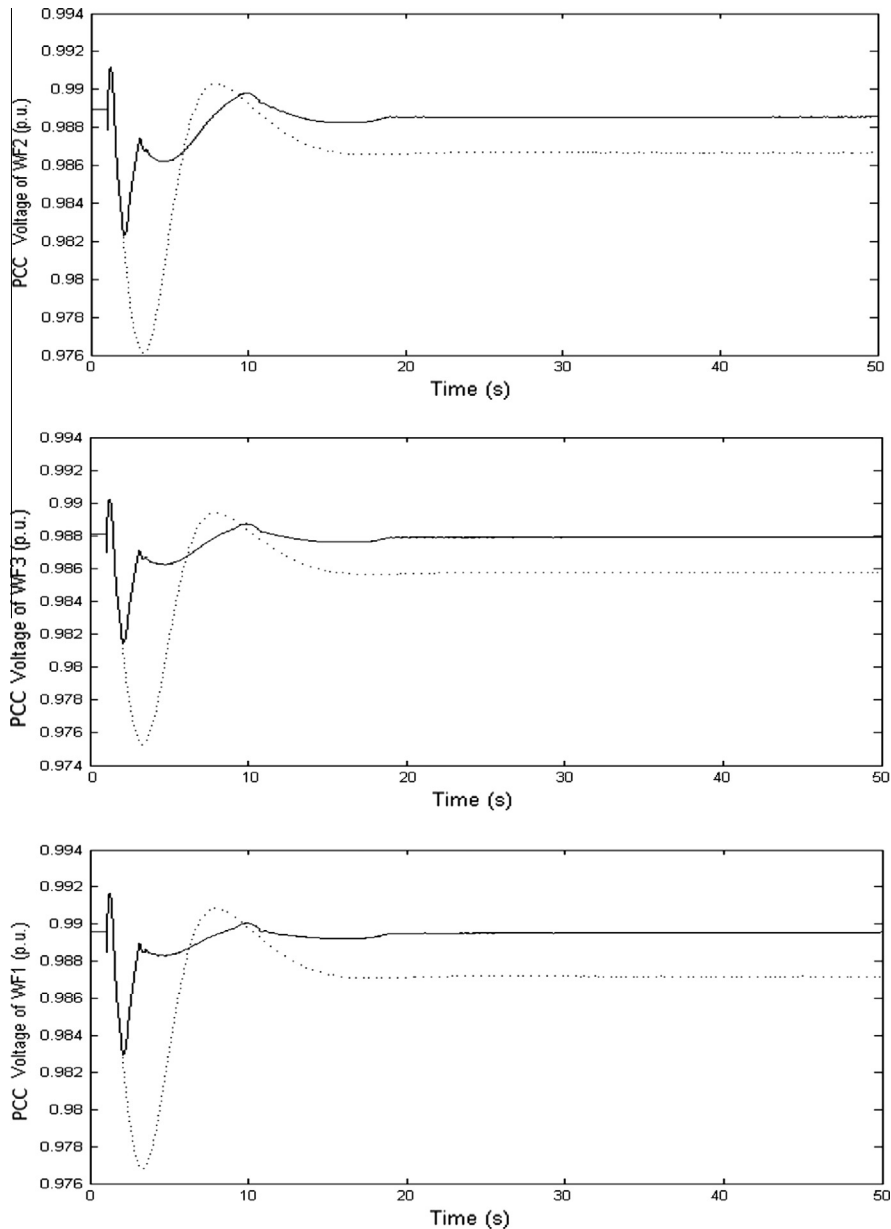

**Fig. 9.** The PCC voltage performance of wind farms for scenario one, fuzzy coordinator (solid), conventional AVR and PSS (dotted).

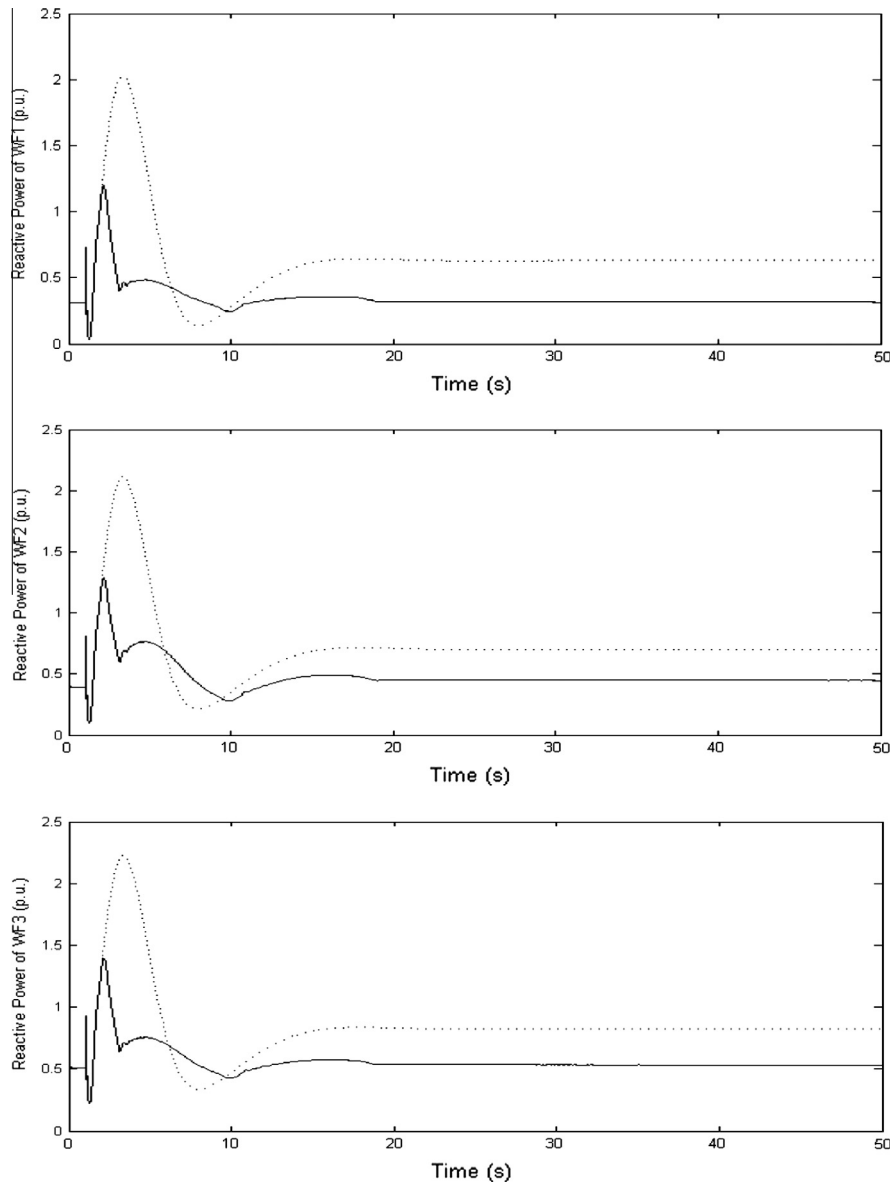

**Fig. 10.** Reactive power in PCC of wind farms for scenario one, fuzzy coordinator (solid), conventional AVR and PSS (dotted).

constitutes of wind turbine with pitch angle controller, a wound rotor induction generator and variable frequency converters. The stator of induction generator in DFIG is directly coupled to the grid, whereas the generator rotor is connected through back-to-back variable frequency converters. The employed power electronic converter at the heart of DFIG plays a vital role to control the rotor current to extract maximum energy from the wind in all conditions. On the other hand, these power electronic converters have power rating about 25–30% of the DFIG's generator capacity. So, this concept has more attractive from the point of economic. The detailed model and parameters data about the DFIG simulation in this paper are given in [23].

#### Test case power system

In this paper, a network with same topology as known New England power system is considered as the test system. This power system with 39 busses concludes 10 generators, 19 loads, 34 transmission lines and 12 transformers. The 39-bus test case power system is widely used as a standard system for demonstrating the

efficiency of new control strategies in large-scale power systems over the years. The single-line diagram of this system is shown in Fig. 2. The system numerical data and parameters that used for simulation can be found in [24].

#### AVR and PSS

All generators of 39-bus power system are equipped with AVR and PSS in this research. The AVRs are added to generation units to keep the terminal voltage at a fixed per unit value. In other words, the AVR provides controllability for the terminal voltage of the generator to which it is attached. Also, the AVRs cause stable operation of power system when it encounters with severe disturbances [21]. As illustrated in Fig. 3, a first order model of a static type is employed for the AVRs in this paper. Early, the synchronous generators utilized AVR merely in power systems. With appearance of frequency and voltage oscillations, the generators equipped with PSSs as the second controller to enhance the small signal stability. The operating function of a PSS is to produce a proper torque on the rotor of the generator that involved, in such a way that the

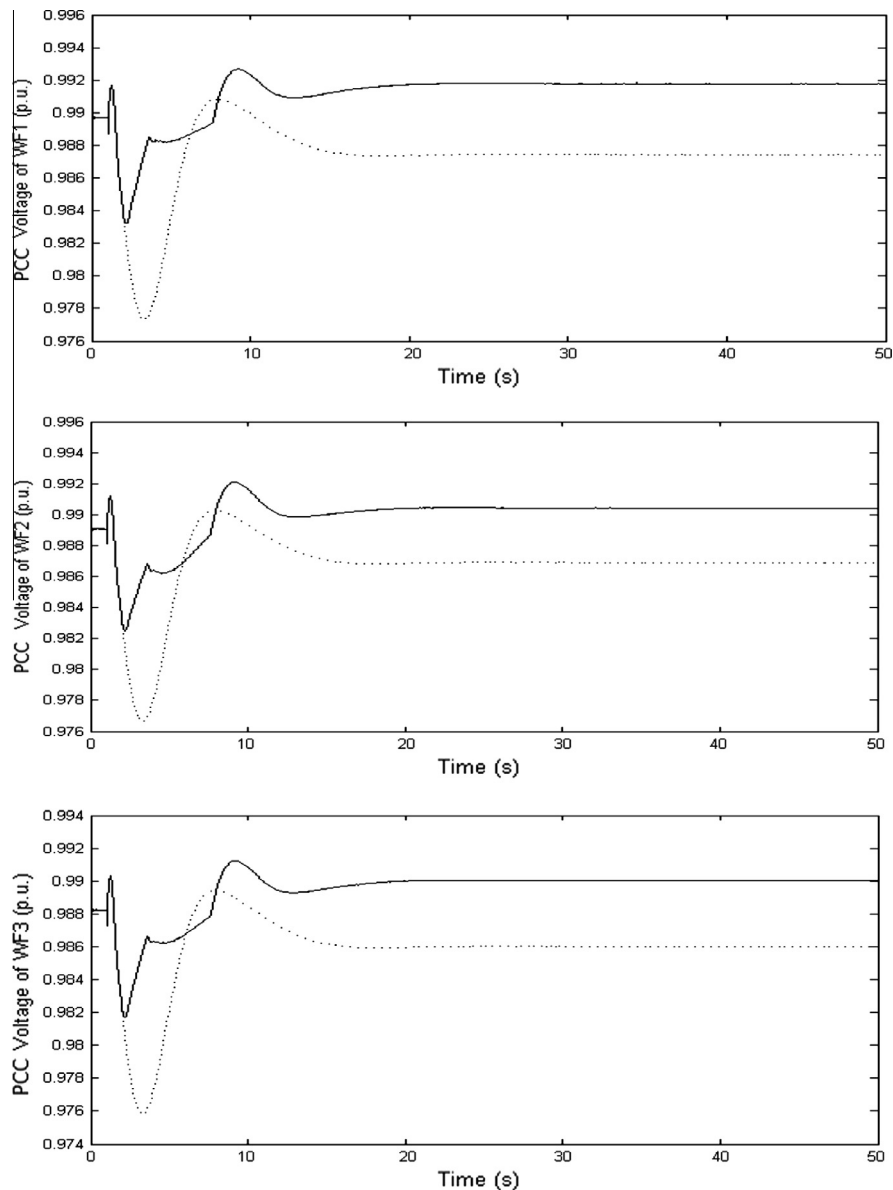

Fig. 11. The PCC voltage performance of wind farms for scenario two, fuzzy coordinator (solid), conventional AVR and PSS (dotted).

phase lag between the exciter input and the machine electrical torque is compensated [25]. The conventional form with two lead-lag transfer functions that used for PSS modeling in this paper are shown in Fig. 4.

### Coordination necessity

Lack of synchronizing/damping torque or both of them result in system instability. Before widespread application of AVRs in power system, instability mainly occurred due to the lack of synchronizing torque. This type of instability was manifested in the form of aperiodic drift of rotor angle of synchronous machines. Installed AVRs in generation units compensate lack of synchronizing torque in power system. Other types of instability resulted in the lack of damping torque as sustained or increased oscillations of rotor angles [26]. Regarding to these states, the AVRs affect performance of power system by improving transient stability. On the other hand, as addressed in [27], while a high-gain fast-response AVR improves the transient stability it also has detrimental effect on small signal stability. As a supplementary controller, PSS is

employed to produce an auxiliary damping torque to eliminate low frequency oscillations. A well-tuned PSS can deteriorate the action of the AVR [27].

The AVRs and PSSs produce torques in phase with rotor angle variations and speed variations, respectively. However, both AVR and PSS employ field voltage to produce the torques which are not in phase. In other word, a control signal is applied to generator to satisfy two conflict control actions. As highlighted in Fig. 5, the AVR and PSS controllers enhance the oscillation damping and voltage stability, simultaneously through one direction. However, an enhancement in one direction may cause deterioration of the other direction. Therefore, a tradeoff between AVR and PSS control action seems to be necessary.

The coordination problem is investigated in literature. To achieve this goal [28], employed a new robust control methodology design to resisting the AVR-PSS system against severe faults. In [29], the conventional structure of system has been changed to coordinate the control system. Bode frequency response with a step-by-step algorithm is addressed in [30] to create a trade-off between AVR and PSS. The proposed control strategy in the present

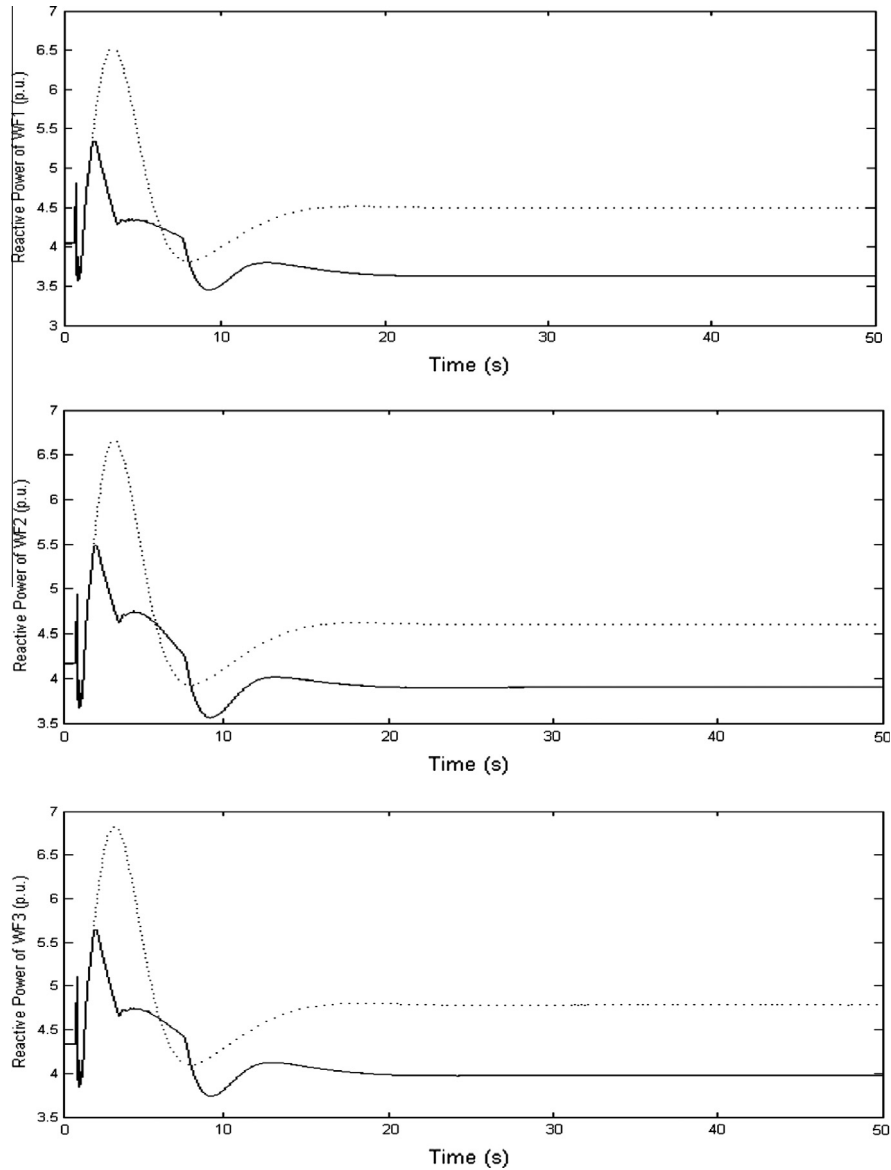

Fig. 12. Reactive power in PCC of wind farms for scenario two, fuzzy coordinator (solid), conventional AVR and PSS (dotted).

work to coordinate AVR and PSS is based on the given ideas in [31,34,35].

### Fuzzy coordinator

Fuzzy logic approach is an artificial method in decision making and it is able to compensate the inability of the classic control theory for covering the complexity and nonlinearity of physical systems with their uncertainties and inaccuracies. Because of that, the fuzzy logic can be considered as a powerful tool for solving the stability problems of power systems [32]. Typically, to design a controller based on the fuzzy approach for dynamic systems, following steps should be considered [33]:

Step (1) Understanding of the system dynamic behavior characteristics. Define the states and input/output control variables and their variation ranges.

Step (2) Identify appropriate fuzzy sets and membership functions. Create the degree of fuzzy membership function for each input/output variable and complete fuzzification.

Step (3) Define a suitable inference engine. Construct the fuzzy rule base, using the control rules that the system will operate under. Decide how the action will be executed by assigning strengths to the rules.

Step (4) Determine defuzzification method. Combine the rules and defuzzify the output.

The AVR and PSS controllers are essentially designed for the nominal operating point of the system and for fault conditions it needs to have trade-off between these controllers. In this research, the fuzzy unit works as a coordinator between AVR and PSS controllers. A fuzzy system is composed of four main sections: fuzzification, fuzzy rule base, inference system and defuzzification. The proposed control framework for application of fuzzy controller in this paper has two inputs and two outputs. The main interest is on the input signals for the fuzzy unit. Terminal voltage deviation and rotor phase difference can be selected as the input signals. But it is noteworthy that, after severe disturbances the terminal voltage and rotor phase of the generators may change seriously. A normalization method is applied to limit these deviations. The



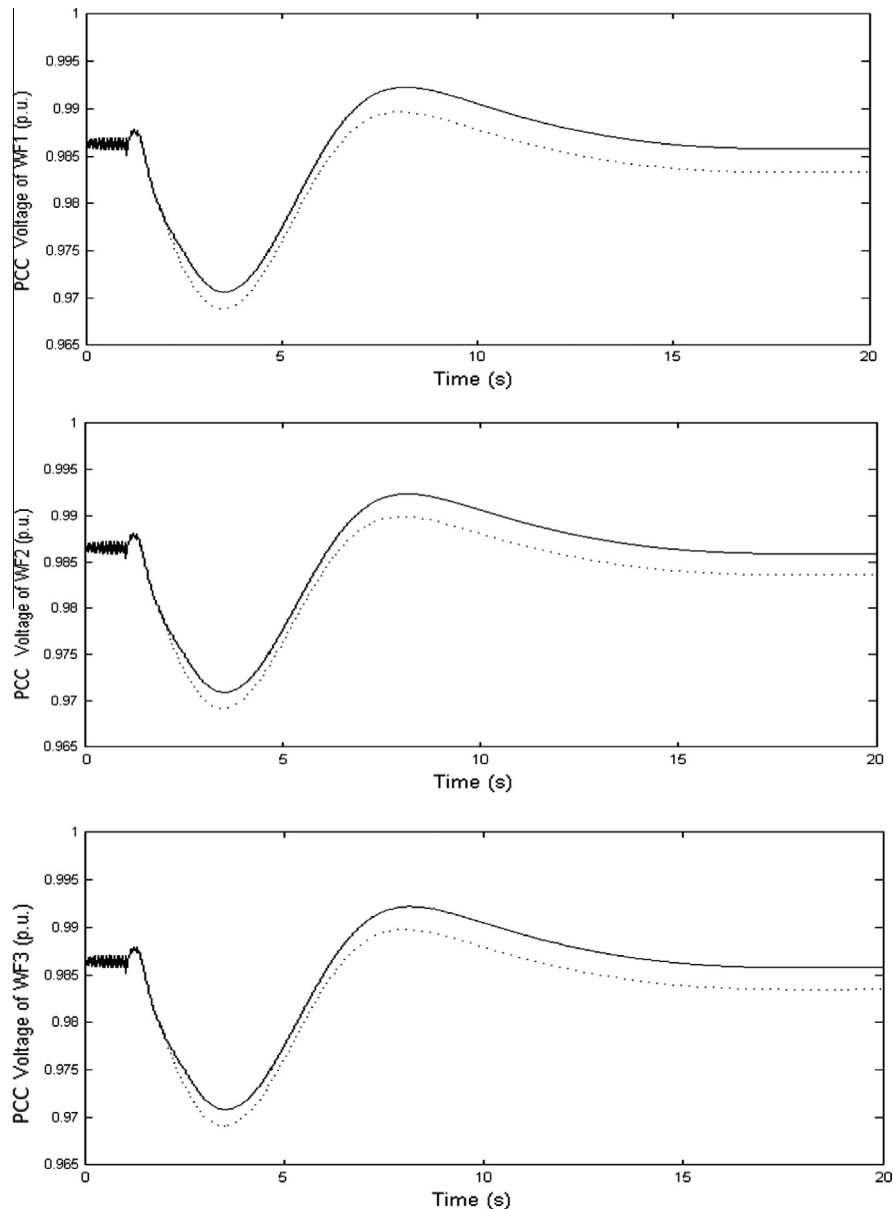

Fig. 13. The PCC voltage performance of wind farms for scenario three, fuzzy coordinator (solid), conventional AVR and PSS (dotted).

normalization method has been illustrated in Fig. 6 for given parameters ( $X$ ). Also, Fig. 7 shows the fuzzy coordinator with input and output signals.  $\Delta\delta_i$  and  $\Delta V_i$  demonstrate the normalized phase difference and terminal voltage deviations. The  $\Delta\delta_i$  and  $\Delta V_i$  can change in range of  $[-1, 1]$  for all generators. The membership functions of the input and output signals are arranged based on trapezoid method. In this paper, the membership functions corresponding to the input and output variables are arranged as Negative Large (NL), Negative Small (NS), Zero (ZR), Positive Small (PS) and Positive Large (PL). In the present investigation, five membership functions are defined for the input signals and output signals. The membership functions for input and output variables are same and demonstrated in Fig. 8. The Mamdani inference system is also used for the proposed fuzzy. The performed fuzzy rules are given in Table I.

The prominent feature of this fuzzy coordinator is its simplicity. Ref. [34] uses the fuzzy coordinator to create coordination between AVR and PSS for stability enhancement of multi-machine power system. However, in this paper, the coordination obligation of

fuzzy coordinator is to mitigate the voltage performance in terminal of DFIG-based wind turbines in large-scale power system.

### Simulation results

As explained, the fuzzy logic-based controller works as a coordinator for AVR and PSS to create a trade-off between these two conventional controllers. The main objective of this coordination is to mitigate voltage performance in DFIG-based wind turbine terminal in fault situations. According to normalization process of terminal voltage and rotor angle deviations of synchronous generators, the investigated power system should have more than two synchronous generators. The 39-bus IEEE standard power system is selected as a large-scale power system with 10 generators in this research. Considering economic constraints, installation of the fuzzy coordinator on all of synchronous generators of a multi-machine power system seems irrational. Thus, the fuzzy coordinator should be installed on influential generators in the system.



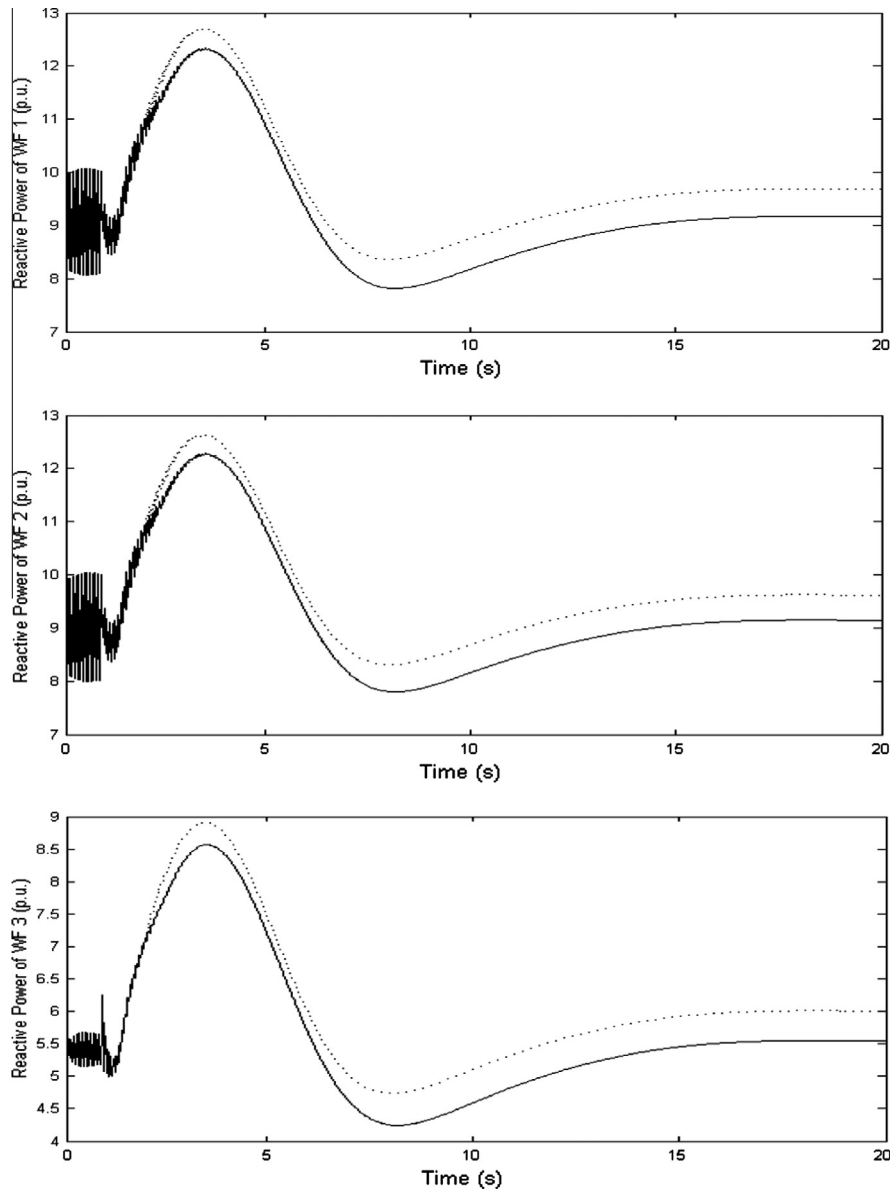

Fig. 14. Reactive power in PCC of wind farms for scenario three, fuzzy coordinator (solid), conventional AVR and PSS (dotted).

Generators with maximum generation capacity can be considered as an appropriate selection to equip with fuzzy coordinator. The 39-bus power system has three control areas; so, significant generator in each area should be selected. Generator number 1 in area one, generator number 9 in area two and generator number 6 in area three have the most generation capacity in each area. Therefore, the fuzzy coordinators are installed on these three synchronous generators. Simulation results show that, by installing fuzzy coordinator on generators number 1, 6 and 9, the voltage performance of system is enhanced. In these generators, the fuzzy coordinator with receiving the normalized deviations of terminal voltage and rotor angle of synchronous generator optimizes the AVR and PSS gains in fault situations.

The DFIG-based wind farms equally divided in each areas of the 39-bus power system. It is assumed that, several DFIGs are lumped to obtain each wind farm in the system. These wind farms are connected to the network through transformers and transmission lines. In fault situations, voltage dips are appeared in the PCC of

wind farms. These voltage dips at the terminals of DFIG-based wind farms can disconnect them from network or destroyed their converters. Therefore, the voltage dips should be mitigated after fault occurrence using additional controllers to ensure safe performance of wind farms and power system.

Fuzzy rules are adjusted so that, the coordinator generates the optimized gains for AVR and PSS to mitigate the voltage performance in the PCC of DFIG-based wind farms. Three scenarios have been investigated to demonstrate the efficiency of fuzzy coordinator for voltage performance enhancement. In the scenarios, level and mode of penetration of DFIG-based wind farms in large-scale power system are changed. For the first and second scenarios the wind farms infiltrate in non-generator busses of the power system. For these scenarios, the penetration level for each area of 39-bus power system is equal. Furthermore, in the third scenario synchronous generators are replaced with the DFIG-based wind farms in the system. Simulation results illustrate that, the fuzzy coordinator with same membership functions and rules, gives

appropriate performance for voltage performance in the PCC of DFIGs for different scenarios. In all scenarios, sudden increase of 75 MW load is simulated as fault; and it occurs in the first second of simulation.

#### Scenario one (10% penetration)

The DFIG-based wind farms are added to buses 5, 16 and 26. The total installed capacity in whole system is 840 MW for conventional synchronous generators. Also, the total generation capacity for wind farms is 90 MW in this scenario; 30 MW wind farm in each area.

The voltage performance of the PCC in wind farms are demonstrated in Fig. 9 for conventional AVR-PSS and fuzzy coordinator. As illustrated, the voltage performance is enhanced and the recovery becomes faster with the fuzzy coordinator. Furthermore, it is observable that, the voltage profile has lesser under-shoot and the steady state is enhanced with fuzzy coordinator. Also, the reactive power consumption of DFIG-based wind farms is reduced after fault occurrence. The reactive power of DFIG-based wind farms terminals are shown in Fig. 10.

#### Scenario two (20% penetration)

In this scenario the penetration level of wind farms is increased to 20% of generation capacity of synchronous generators; 60 MW active power generation for each wind farm in the system. In this scenario each wind farm consists of two DFIG-based wind turbines and it is assumed that several DFIG-based wind generators are lumped together to obtain each one.

The membership functions and fuzzy rules are not changed for this scenario. As it is conventional in practice, the fuzzy rules should be optimized for each scenario in the system. But the designed fuzzy coordinator in this paper gives appropriate performance for other scenarios.

The voltage performance in the PCC of wind farms are illustrated in Fig. 11 for adding 75 MW load in the system at the first second. Similar to scenario one, the voltage performance is enhanced with fuzzy coordinator. The voltage profile has lesser under-shoot, enhanced steady state value and the recovery becomes faster. The reactive power in terminals of wind farms are depicted in Fig. 12. As illustrated, fuzzy coordinator significantly improves the performance of conventional AVR and PSS.

#### Scenario three (25% penetration)

In previous scenarios the efficiency of fuzzy coordinator for conventional penetration of wind farms was illustrated. In this scenario synchronous generators are replaced with the DFIG-based wind farms in the system. The generating units 3, 4 and 5 are replaced with wind farms 1, 2 and 3.

Generation capacity of these three generators is equal to 213 MW (G3: 75 MW, G4: 73 MW and G5: 65 MW). This level of penetration is about 25% of the whole generation capacity of synchronous generators in the system. With replacement of DFIGs instead of the synchronous generators in the system, the system inertia reduces. The lower system inertia leads to faster changes in the system responses. It is expected that, diminish in synchronous generators impacts on the performance of fuzzy coordinator. Similar to previous scenario, fuzzy membership functions and fuzzy rules are not optimized for this scenario.

The voltage performance in the PCC of DFIG-based wind farms are illustrated in Fig. 13. As shown in this figure, the voltage performance is enhanced after fault occurrence. The fuzzy coordinator maintains its efficiency and effectiveness. The reactive power in PCC of DFIGs is demonstrated in Fig. 14. As shown, the reactive

power profile is enhanced using fuzzy coordinator for replacement of DFIGs in the system.

## Conclusion

Large extension of DFIGs in power systems needs appropriate work conditions. Among the essential requirements for DFIG-based wind farms, voltage performance in fault situations is the utmost important one. In this paper, the control of synchronous generators is used for voltage performance enhancement in the PCC of DFIG-based wind farms. An optimal trade-off between AVR and PSS using fuzzy logic is the main task of this research. The AVR and PSS controllers enhance the stability and improve voltage regulation through a unit signal. Hence, in the fault situations an enhancement in one may cause deterioration of the other. Therefore, a tradeoff between AVR and PSS is performed to enhance the voltage performance of system. On the other hand, the efficiency of trade-off is illustrated at the presence of DFIG-based wind farms in three scenarios.

The fuzzy logic methodology is employed to create coordination between AVR and PSS. The fuzzy coordinator receives the normalized deviations of voltage terminal and rotor angle of synchronous generators, and adjusts the AVR and PSS gains to enforce them to provide desirable performance in fault situations.

The efficiency of fuzzy coordinator is investigated in three scenarios of DFIG-based wind farms penetration in IEEE 39-bus standard power system. The voltage performance in PCC of wind farms is enhanced with fuzzy coordinator and voltage profile had lesser under-shoot, enhanced steady state value and the recovery become faster. Also, the reactive power consumption was reduced in the PCC of wind farms.

## Acknowledgement

The authors would like to thank H. Golpira and P. Daneshmand for their valuable technical assistance.

## References

- [1] Ellabban O, Abu-Rub H, Blaabjerg F. Renewable energy resources: current status, future prospects and their enabling technology. *Renew Sustainable Energy Reviews*, vol. 39. Elsevier; 2014. pp. 748–764.
- [2] Yuan X. Overview of problems in large-scale wind turbines. *Journal of Modern Power System and Clean Energy*. Springer; 2013. pp. 22–25.
- [3] Smith JCh, Milligan MR, DeMeo EA, Parsons B. Utility wind integration and operating impact state of the art. *IEEE Trans Power Syst* 2007;22(3):900–8.
- [4] Shi L, Dai S, Ni Y, Yao L, Bazargan M. Transient stability of power systems with high penetration of DFIG based wind farms. *Power Energy Soc Gen Meet* 2009:1–6.
- [5] Qiao W, Harley RG. Effect of grid-connected DFIG wind turbines on power system transient stability. *Power Energy Soc Gen Meet* 2008:1–7.
- [6] Gautam D, Vittal V, Harbour T. Impact of increased penetration of DFIG-based wind turbine generators on transient and small signal stability of power systems. *IEEE Trans Power Syst* 2009;24(3).
- [7] Muljadi E, Butterfield CP, Allis A. Effect of variable speed wind turbine generator on stability of a weak grid. *IEEE Trans Energy Conv* 2007;22(1).
- [8] Vittal E, O'Malley M, Keane A. Rotor angle stability with high penetrations of wind generation. *IEEE Trans Power Syst* 2012;27(1).
- [9] Morren J, de Haan SWH. Ride through of wind turbines with doubly-fed induction generator during a voltage dip. *IEEE Trans Energy Conv* 2005;20(2):435–41.
- [10] Hossein MJ, Saha TK, Mithulananthan N, Pota HR. Control strategies for augmenting LVRT capability of DFIGs in interconnected power systems. *IEEE Trans Ind Electr* 2013;60(6).
- [11] Vittal E, O'Malley M, Keane A. A steady-state voltage stability analysis of power systems with high penetration of wind. *IEEE Trans Power Syst* 2010;25(1):433–42.
- [12] Xie D, Xu Z, Yang L, Ostergaard J, Xue Y, Wong KP. A comprehensive LVRT control strategy for DFIG wind turbines with enhanced reactive power support. *IEEE Trans Power Syst* 2013;28(3):3302–10.
- [13] Rahimi M, Parniani M. A efficient control scheme of wind turbines with doubly fed induction generators for low-voltage ride-through capability enhancement. *IET Renew Power Gen* 2010;4(3):242–52.

- [14] Hughes FM, Anaya-Lara O, Jenkins N, Strbac G. Control of DFIG-based wind generation for power network support. *IEEE Trans Power Syst* 2005;20(4):1958–66.
- [15] Kumar NS, Gokulakrishnan J. Impact of FACTS controllers on the stability of power systems connected with doubly fed induction generators. *Int J Electr Power Energy Syst* 2011;33:1172–84.
- [16] Hossain MJ, Pota HR, Mahmud MA, Ramos RA. Investigation of impacts of large-scale wind power penetration on the angle and voltage stability of power systems. *IEEE Syst J* 2012;6(1).
- [17] Qiao W, Venayagamoorthy GK, Harley RG. Real-time implementation of a STATCOM on a wind farm equipped with doubly fed induction generators. *IEEE Trans Ind Appl* 2009;45(1).
- [18] Wang L, Truong D. Stability enhancement of DFIG-based offshore wind farm fed to a multi-machine system using a STATCOM. *IEEE Trans Power Syst* 2013;28(3).
- [19] Qiao W, Harley RG, Venayagamoorthy GK. Coordinated reactive power control of a large wind farm and a STATCOM using heuristic dynamic programming. *IEEE Trans Energy Conv* 2009;24(2).
- [20] Chompoo-inwai C, Yingvivanapong C, Methaprayoon K, Lee W. Reactive compensation techniques to improve the ride-through capability of wind turbine during disturbance. *IEEE Trans Ind Appl* 2005;41(3):1.
- [21] Kundur P. *Power system stability and control*. New York: McGraw-Hill; 1994.
- [22] Demello FP, Concordia C. Concepts of synchronous machine stability as effected by excitation control. *IEEE Trans Power Appar Syst PAS-88* 1969;316–29.
- [23] GE energy. Modeling of GE wind turbine-generators for grid studies, version 3.4b; March 2005.
- [24] Bevrani H, Daneshfar F, Daneshmand PR. Intelligent power system frequency regulation concerning the integration of wind power units. In: Wang LF, Singh C, Kusiak A, editors. *Wind power systems: applications of computational intelligence*. Heidelberg, Germany: Springer-Verlag; 2010. p. 407–37.
- [25] Larsen EV, Swann DA. Applying power system stabilizers part I: general concepts. *IEEE Trans Power Appar and Syst PAS-100* 1981(6):3017–24.
- [26] Golpira H, Naghshbandi AH, Bevrani H. A survey on coordinated design of voltage regulator and power system stabilizer. *Int Rev Autom Control (IREACO)* 2010;3:172–82.
- [27] Dudgeon GJW, Leithead WE, Dysko A, O'Reilly J, McDownload R. The effective role of AVR and PSS in power systems: frequency response analysis. *IEEE Trans Power Syst* 2007;22(4):1986–94.
- [28] Bevrani H, Hiyama T. Power system dynamic stability and voltage regulation enhancement using an optimal gain vector. *Control Eng Pract* 2008;16:1109–19.
- [29] Boules H, Peres S, Margotin T, Houry MP. Analysis and design of a robust coordinated AVR/PSS. *IEEE Trans Power Syst* 1998;13(1):568–75.
- [30] Dysko A, Leithead WE, O'Reilly J. Enhanced power system stability by coordinated PSS design. *Power Syst* 2010;25(1):413–22.
- [31] Golpira H, Bevrani H, Naghshbandi AH. Approach for coordinated automatic voltage regulator and power system stabilizer design in large-scale interconnected power systems considering wind power penetration. *IET Gen Trans Dist* 2012;1(6):39–49.
- [32] Hua SY, Allen TJ. Application of fuzzy logic in power systems. I. General introduction to fuzzy logic. *Power Eng J* 1997;11(5):219–22.
- [33] Bevrani H, Hiyama T. *Intelligent automatic generation control*. New York: CRC; 2011.
- [34] Khezri R, Bevrani H. Fuzzy-based coordinated control design for AVR and PSS in multi-machine power systems. In: 13th Iranian conference on fuzzy systems; 2013. p. 1–5.
- [35] Bevrani H, Watanabe M, Mitani Y. *Power system monitoring and control*. NY: IEEE-Wiley; 2014.
- [36] Bevrani H, Ghosh A, Ledwich G. Renewable energy sources and frequency regulation: survey and new perspectives. *Renew Power Gen, IET* 2010;4(5):438–57.